

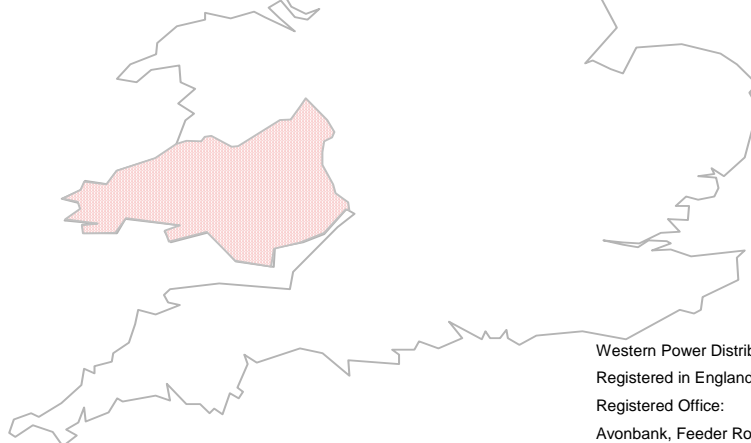

Proposed for Approval
Statement of Use of System
Charging Methodology for
Western Power Distribution
(South Wales) plc
(December 2007)

With IDNO changes



Western Power Distribution (Wales) plc
Registered in England and Wales No.2366985
Registered Office:
Avonbank, Feeder Road, Bristol BS2 0TB

Price: £5.00 plus VAT

Contents

	Page
Licence Obligations	3
Price Control	4
Use of System	4
Connection and Use of System Boundary	4
The Contractual Framework	4
Contact Details	6
Principles	6
Methodology	9
Demand Use of System Charges for LV, HV and EHV Networks	9
- Long Run Incremental Cost Methodology	9
- Calculation of Tariff Yardsticks for HV and LV Networks	12
- Reconciliation of LRIC and DRM output to required revenue	14
- Setting Prices using the LRIC/DRM Model	14
Generator Use of System Prices at HV and LV	15
- Model Inputs and Assumptions	15
- Model Outputs	16
- Price Setting	16
Incentive for Network Access - HV and EHV connected generators	17
Glossary	19
Appendix 1 Example of LRIC Methodology	21
Appendix 2 Example of Yardstick Methodology	23
Appendix 3 Loss Adjustment Factor Methodology	24

WESTERN POWER DISTRIBUTION (Wales) plc

STATEMENT OF USE OF SYSTEM METHODOLOGY FOR WESTERN POWER DISTRIBUTION (WALES) plc

(December 2007)

Licence Obligations

This statement describes the methodology that Western Power Distribution (Wales) plc (WPD (Wales) plc) employs to set charges for use of its electricity distribution system for the purposes of transporting electricity.

The statement is prepared by WPD (Wales) plc in accordance with the requirements of Condition 4, paragraph 1(a), of its Electricity Distribution Licence issued under the Electricity Act 1989 as amended by the Utilities Act 2000. We are also obliged to review our Use of System Charging Methodology annually in accordance with Licence Condition 4, paragraph 2(a) and in order to comply with paragraph 2(b), make such modifications to the Use of System Methodology Statement that better achieve the relevant objectives as defined in paragraph 3. These are:

“(a) that compliance with the use of system charging methodology facilitates the discharge by the licensee of the obligations imposed on it under the Act and by this licence;

(b) that compliance with the use of system charging methodology facilitates competition in the generation and supply of electricity, and does not restrict, distort or prevent competition in the transmission or distribution of electricity;

(c) that compliance with the use of system charging methodology results in charges which reflect, as far as is reasonably practicable (taking into account of implementation costs), the costs incurred by the licensee in its distribution business; and

(d) that, so far as is consistent with sub-paragraphs (a), (b) and (c), the use of system charging methodology, as far as is reasonably practicable, properly takes account of developments in the licensee’s distribution business.”

Words and expressions used in this statement have (unless specifically defined herein) the definitions given to them in the Acts or the Licence and shall be construed accordingly. Charges and costs are current at the time of publication and will not be changed, except as provided for in the relevant agreement for use of system (see below) and subject to Condition 4 of the Licence.

This statement has been approved by the Gas and Electricity Markets Authority (the Authority). Future modifications will also be subject to approval by the Authority.

A fee of £5 plus VAT will be payable for each copy of this statement which is provided in accordance with a request. Copies may also be downloaded free of charge from WPD’s website at www.westernpower.co.uk.

Price Control

WPD (Wales) plc is a licensed distribution business and the Authority regulates it. The regulation is applied via the Distribution Licence and the price control mechanism. The price control period is 5 years and Ofgem prescribe the amount of revenue that WPD (Wales) plc is allowed to recover from its customer base annually and over the price control period. Use of System charges may vary year on year as WPD (Wales) plc sets its use of system charges to recover its allowed revenue.

Use of System

WPD (Wales) plc will levy use of system charges for utilisation of its network for the supply of electricity to end users. WPD (Wales) plc's Use of System tariffs are published in our Statement of Charges for Use of System.

Connection and Use of System Boundary

WPD (Wales) plc splits the recovery of costs between connection to the distribution network and on-going use of system charges for utilisation of the network. This boundary point is common for both demand and generation customers. This statement contains the charging methodology that is applied for the calculation of use of system charges and the Statement of Charges for Use of System details the use of system charges that are applied. The Statement of the Basis of Charges for Connection details the Connection Charging Methodology that is used for calculation of connection charges and demonstrates the areas of cost that are recovered through connection charges. The latter statement also contains indicative charges and examples to aid understanding of connection charges. These statements can be obtained from our website, www.westernpower.co.uk, or available on request at a cost of £5 from the address for contact given in the Use of System Charging statement.

The Contractual Framework

Persons entitled to use WPD (Wales) plc's system are those who are authorised by Licence or by exemption under the Act to supply or generate electricity (Suppliers or Generators). In order to protect all users of the system, WPD (Wales) plc will require evidence of authorisation prior to agreeing terms for use of the system.

NOTE: In the rest of this commentary, requirements applying to authorised persons should be taken to mean Licensed Suppliers or Licensed Generators only.

Persons seeking to use the system will be required, prior to using the system, to enter into an Agreement with WPD (Wales) plc setting out the obligations of both parties. The party seeking use of the system will be required to:

- pay all charges due in respect of use of system as described in this statement and the accompanying schedules;
- be a party (where the person is a Licensed Supplier) to the Master Registration Agreement (MRA) for the provision of metering point administration services within WPD (Wales) plc's authorised area;
- enter into the National Grid Electricity Transmission (NGET's) Connection and Use of System Code and any necessary Bilateral Agreement, governing connections to

and use of NGET's transmission system, unless WPD (Wales) plc is informed by NGET that this is not required in any particular case;

- be a party to the Balancing and Settlements Code;
- comply with the provisions of the Distribution Code, a copy of which may be accessed on Western Power Distribution's website (www.westernpower.co.uk) or purchased from WPD (Wales) plc at a charge of £30 or £50 for a serviced copy in the first year of a five year Distribution Price Control Period (reducing by £4 each year for requests starting in later years in the five year period), plus postage and VAT.

If the applicant and WPD (Wales) plc within a reasonable time fail to agree contractual terms, or any variation of contractual terms proposed by WPD (Wales) plc, either party may request settlement by the Gas and Electricity Markets Authority, 9 Millbank, London, SW1P 3GE.

While the terms and conditions in the agreement will be consistent with those in this statement, the agreement will take precedence. Where a Supplier or Generator, having entered an agreement for use of WPD (Wales) plc's distribution system, ceases for whatever reason to be a Supplier or Generator with respect to that use of the system, then the entitlement to use of the system will cease forthwith but the operator will continue to be liable under the agreement unless and until the agreement is terminated. In order to avoid any liability in this regard, a Supplier or Generator wishing to terminate his Agreement or wishing to notify a change should give WPD (Wales) plc no less than 28 days' notice. WPD (Wales) will normally respond within 28 days of a notification of a change.

Terms and conditions for connection of premises or other electrical systems to WPD (Wales) plc's distribution system, and for the provision of distribution metering and data services, are contained in separate statements, which are available from WPD (Wales) plc on request. These statements can be obtained from our website, www.westernpower.co.uk, or available on request at a cost of £5 from the address for contact given in the Use of System Charging statement. Persons seeking use of the system with respect to a new supply must apply for connection in accordance with the terms and conditions described in that statement.

Where a person requires a connection to WPD (Wales) plc's electricity distribution system pursuant to Section 44 of the Utilities Act 2000, the provisions of this statement are without prejudice to the provisions of sections 44 to 50 of the Utilities Act 2000 (those sections which deal with the rights, powers and duties of WPD (Wales) plc, as an electricity distributor), in respect of the distribution of electricity to owners or occupiers of premises.

Contact Details

If you have any questions about the contents of this statement please contact us at the address given in the Use of System Charging statement.

Principles

Pursuant to the requirements of Condition 4 of the Electricity Distribution Licence, the following paragraphs relate to the transport of electricity on WPD (Wales) plc's distribution system by Authorised Suppliers to exit points from the system, and to the transport of electricity on the system for supply to Suppliers and to/from generators including customers with on-site generation.

1. Where a supply of electricity is provided over electric lines or electrical plant comprising a part of WPD (Wales) plc's distribution system, a charge for use of the system will be levied on the Supplier or Generator of the electricity. The relevant charges, which are generally applicable, are described in the Licence Condition 4A statement and are payable by reference to the characteristics of the supply, in accordance with the categories of supply described in the section headed 'General Notes'.
2. The charges for use of the system reflect:
 - the costs to WPD (Wales) plc of providing, operating and maintaining the distribution system to the standards prescribed by the Act and WPD (Wales) plc's Electricity Distribution Licence, other than those costs which are recovered through charges paid to WPD (Wales) plc in respect of connection to the system, such that electricity can be transported efficiently through the system to exit points; and
 - the costs to WPD (Wales) plc of providing certain services and performing functions for Supplier or Generators, on terms which WPD (Wales) plc is under a duty to offer under its Electricity Distribution Licence, in order to support the operations of a fully competitive supply market in its authorised area. These services include: Metering Point Administration Services; Energisation and De-energisation and Re-energisation services; and Radio Teleswitch Services. WPD (Wales) plc is either wholly or partly remunerated through use of system charges or through transaction charges for these services. The cost for provision of these services is detailed in our Licence Condition 4A Statement.

All charges for use of the system include a reasonable return on the relevant assets, and the revenues arising from the charges are subject to regulation in accordance with the terms of the Licence.

3. The charges reflect real electrical flows on the system and the need to provide adequate capacity at all voltage levels to protect the security of the system. Charges are applied to the electricity as measured at the exit points for the whole of the site.
4. Depending on the tariff, the charges for use of the system may include some or all of the following elements:

- **standing charges** to cover the costs that do not vary with the extent to which the supply is taken up;
 - an **availability charge** to cover capacity on the local distribution system, which is attributed to the supply in the case of LV and HV supplies;
 - **unit charges** per kWh unit delivered to the exit point from the system, designed to reflect use of the system at all relevant voltages;
 - an **excess reactive unit charge** per kVArh unit delivered to the exit point from the system. The excess reactive power charge provides a behavioural pricing signal to customers to improve their power factor. Reactive power charges are applied only to those customers who exhibit poor power factors; and
 - **transactional charges** for certain services provided by WPD (Wales) plc on an individual basis to Licensed Suppliers. Details are given in our Statement of charges for Use of System in Schedules 2 to 4 inclusive.
 - **operation and maintenance charges** to cover operation and maintenance of sole use assets.
 - a **network access rebate** for generators which provides rebates for network unavailability.
5. The standing charges for use of the system referenced above may include an amount to reflect the cost of provision of the service cable to the premises and its termination, ongoing repair and maintenance, replacement and a contribution to the costs of the local network except as recovered within the connection charge.
6. Charges for use of the system will be payable in accordance with the billing period and payment terms agreed with the party using the system, normally 14 days after notice. WPD (Wales) plc reserves the right to require appropriate security in respect of the charges estimated to arise depending on the circumstances of the supply and on the basis of the agreed payment terms. Invoices for domestic, small non-domestic and large non-domestic, non-half-hourly settled sites will be calculated according to the Supercustomer methodology for use of system billing, a description of which is given in our Licence Condition 4A Statement. However, for supplies with more complex pricing structures, site specific invoices will be rendered for each site registered to the supplier, listing the supplies to which the invoice refers, the information about the supply on which the charge has been calculated, or the basis on which an estimate has been made, and the amount due with respect to each supply identified in the invoice. Additional information derived from the metering can be provided on terms to be agreed.

7. Where a supply is to be provided wholly or partly over WPD (Wales) plc's distribution system to an exit point from that system, the supplier must demonstrate that at all times the quantity of electricity entering the system for the purposes of providing that supply equals the metered quantity delivered from the system to that exit point plus the amount of electrical losses appropriate to the voltage at which the supply is delivered and to the source of the supply as shown in the schedule of loss adjustment factors (Schedule 5) of our Licence Condition 4A Statement. WPD (Wales) plc is regulated on total electrical losses on its system through a yardstick in the Licence price condition, and the adjustment factors in Schedule 5 are an allocation of the total. Relevant metering information or membership of the Balancing & Settlement Code will be considered to be adequate demonstration. Suppliers should refer to Schedule 5 to calculate the amount of electricity which they must provide. The same loss adjustment factors are reflected automatically in the settlement system.
8. Where the supply is to be provided over WPD (Wales) plc's distribution system on either an intermittent or continuing basis to any premises with own generation, charges for use of the system will be levied with respect to the system capacity provided to meet the maximum power required to be supplied to the premises as requested by the party seeking use of the system and the extent to which that supply is taken up. These take the form of availability charges.
9. Where, after evaluation of the characteristics of the requested use of the system, WPD (Wales) plc accepts that none of the categories of charges in the attached schedules is appropriate, WPD (Wales) plc will offer special arrangements. It is expected that these circumstances will be very rare. This may include cases where multiple exit points are separately supplied at a site. In these circumstances, the use of system charges offered will be based on the same principles to those used for determining the charges in the schedules and will include some or all of the elements detailed in paragraph 4. WPD (Wales) plc will endeavour to make its offer of terms within 28 days of receiving the application.
10. For supplies provided at EHV or for premises with demands close to or above 10MW, use of system charges at the voltage of connection will be individually costed to take account of the specific WPD (Wales) plc connection assets employed in providing connection. For sites of this type, the charges will include an appropriate component to meet the charges levied on WPD (Wales) plc by the National Grid Electricity Transmission plc in respect of Exit Charges at Grid Supply Points.
11. Where use of the system is sought at a standard of security different from that referred to in the Distribution Code, WPD (Wales) plc may consider special arrangements with respect to that supply. Special arrangements may apply also to supplies/loads with power factors of less than 0.8. In such cases, specially assessed loss adjustment factors may also apply at WPD (Wales) plc's discretion.

12. In all cases for demand use of system, use of system charges include a contribution towards recovery of NGET's connection (exit) charges in respect of the provision by them of WPD (Wales) plc's Grid Supply Points.
13. Use of System charges exclude charges for the provision of non-half hourly distributor metering and data services that are published separately in the "Statement of the Basis of Charges for Metering and Data Services provided by Western Power Distribution (Wales) plc". That statement details charges for the provision of disaggregated non-half hourly metering services; Meter Asset Provision (MAP), Meter Asset Maintenance (MAM) and Meter Point Administration Service (MPAS).

Methodology

Use of System Charges for LV, HV and EHV networks

Different methodologies are used to calculate charges for the EHV network and lower voltage networks respectively. EHV networks use a long run incremental costs method (LRIC) and lower voltage networks use a distribution system reinforcement method (DRM). These are described below.

The boundary between the two methods is the lower voltage side busbar of the EHV to HV transformation.

Long run incremental cost methodology

The method calculates the brought forward (or deferred) reinforcement cost as a result of the addition of an increment of demand or generation at each node.

Model inputs

- The EHV network expected to exist in the year that charges are being calculated for. The network is detailed in our Long Term Development Statement (published in accordance with Licence Condition 25)
- The security factors applicable to each asset derived from a full N-1 contingency analysis of the network
- A modern equivalent asset (MEA) value for each element of the EHV network
- An assessment of future reinforcement costs for each element of the EHV network
- Network demands expected for the year that charges are being calculated for.
- Generation exports consistent with the export that can be used to support system security in accordance with P2/6 expected for the year that charges are being calculated for
- The underlying demand and generation growth forecast for the medium term

Calculation

An initial load flow is undertaken and the time that it will take for each component to reach its capacity is evaluated using the underlying load growths. Given these timings, and the future reinforcement costs, a net present value of the future reinforcement cost for the network is calculated using a discount rate equal to the cost of capital assessed by Ofgem as part of the price control (currently 6.9%).

For each node, an increment of demand/generation is added and a new load flow generated. The evaluation of the net present value of the future reinforcement needs is repeated for the network with this increment present. The difference between the initial and incremental study represents the impact on future reinforcement investment and this is represented as an annual £/kVA at each node by multiplying the difference by an annuity factor. The annuity factor reflects the rate of return on investment and an allowance for operation, repairs and maintenance (the latter is currently 0.9%).

A full AC load flow is used in the methodology. The increment used is 0.1 MVA at 0.95 power factor for demand and unity power factor for generation. The assets used to calculate the locational price are those that see a change in flow greater than 1kVA as a result of the increment.

The algorithm used to achieve the above is as follows:

The long run incremental cost at node N is given by

$$LRIC_N = \sum_i \Delta U_i$$

Where:

ΔU_i is the change in the net present value of the future reinforcement cost of the network as a result of the incremental injection ΔP_{in} given by the equation

$$\Delta U_i = A \times V \times \left(\frac{1}{(1+d)^{n2}} - \frac{1}{(1+d)^{n1}} \right)$$

Where:

A is a 40 year annuity calculated as

$$A = \frac{d}{\frac{1}{(1 - (\frac{1}{(1+d)^{40}}))}}$$

V is the cost of the reinforcement when the asset becomes overloaded

d is the discount rate (the regulatory cost of capital of 6.9% is used)

n1 is the original number of years to reinforcement given by

$$n1 = \frac{\log C_i - \log D_i}{\log(1 + r)}$$

Where:

C_1 is the capacity of asset 1

D_1 is the power flow in asset 1 and

r is the expected growth rate

and n_2 is the new number of years to reinforcement following a change in the flow (ΔP_1) through asset 1 as a result of the injection at node N is given by

$$n_2 = \frac{\log C_1 - \log (D_1 + \Delta P_1)}{\log(1 + r)}$$

The above analysis is undertaken for both winter loading conditions and summer loading conditions using the appropriate ratings for the season.

Detailed model input assumptions

EHV network used - the EHV network used is the existing and committed network that is expected to exist in the December of the year that charges are to be calculated for. New connections expected to connect during the year that charges are being calculated for will only be included where a connection offer has been accepted and all consents have been obtained. A further set of charges will be calculated using customers' loads/generation for all those with accepted connection offers. The network model will include any changes required to accommodate these loads/generation. This enables potential users to see the charges they will incur if their connection proceeds and allows existing users to see the potential impact on their charges in future years. These additional charges will be published separately to our condition 4A charging statement. Where there is expected to be a system overload, for example due to a derogation the expected system changes to resolve the overload are included in the network mode used for charging purposes.

Demands used – for the winter peak demands, the model uses demands consistent with those used to assess reinforcement. This includes diversity to allow a complete EHV system model to be run. Summer minimum demands are taken as being a percentage of winter peak demands. This percentage is derived for each GSP and applied to the demands supplied by that GSP. These are consistent with the annual data we provide to NGET under the Grid Code.

Generation Exports used – the generation export used during the winter period is generally zero unless it is deemed to contribute to security under P2/6. The generation export used for the summer period is the maximum agreed export capacity. These are the same assumptions that are used for investment planning.

Security factors – Security factors have been assessed for each asset using a full N-1 contingency analysis. These factors are recalculated each time the network is changed or new load estimates used.

Growth rates – two underlying growth rates are used to assess future reinforcement timing, one for demand growth and one for generation. To facilitate predictability and stability, the same growth rates are used throughout the model and will only be reset at price controls.

Reinforcement costs – A modern equivalent asset (MEA) value for each element of the EHV network is used. Reinforcement costs are set as a multiple of the MEA value of the asset needing reinforcement. These are derived using data from historic projects and will be reassessed periodically.

An example of how the LRIC method works is shown in attachment 1.

Calculation of site specific charges

For individual EHV connected customers, the winter demand used for charging purposes (winter charging demand) is calculated by weighting together the customers average demands in the time periods ending 17.00, 17.30 and 18.00 during winter weekdays (excluding Christmas and New Year) over the months November to February for the latest year that data is available. The weights used are 38%, 48% and 14% for the half hours ending 17.00, 17.30 and 18.00 respectively and are consistent with those used to derive coincidence factors for lower voltage tariffs. The summer demand used for charging purposes (summer charging demand) for individual EHV customers is the average of their demand in the time periods ending 06.00 on Sundays in the months of July and August. Where the connection is new or significant changes have been made to the agreed capacity a best estimate will be used for the winter charging demand and summer charging demand taking into account the typical ratio seen of agreed supply capacities to charging demands for existing customers.

For connections to other Licence Distributors, the demand used for charging purposes (both winter charging demand and summer charging demand) is that agreed between WPD and the distributor. We would expect this to be the level of capacity necessary to allow them to achieve compliance with their security standard.

For EHV demand sites, the charge is calculated as follows:

- For each branch used by the demand determine whether reinforcement is driven first by winter or summer conditions.
- Where winter, the branch charge is the winter price multiplied by the winter charging demand at the time of peak
- Where summer, the branch charge is the negative of the summer price multiplied by the summer charging demand
- The demand charge is the sum of;
 - the relevant branch charges
 - the annuitised cost of the future replacement value of the sole use assets associated with the connection point
 - the O&M cost associated with the sole use assets associated with the connection point
 - the allocation of network rates

These charges are further adjusted by the revenue reconciliation process described below. Where the resulting demand charge is negative, the scaled marginal £/kVA charge will be set to zero and the overall reconciliation to allowed revenue adjusted accordingly.

For EHV generation sites, the charge is calculated as follows:

- For each branch used by the generation determine whether reinforcement is driven first by winter or summer conditions.
- Where summer, the branch charge is the summer price multiplied by the agreed export capacity
- Where winter, the branch charge is the negative of the winter price multiplied by the P2/6 contribution to security.
- The generator price is the sum of;
 - the relevant branch charges
 - the annuitised cost of the future replacement value of the sole use assets associated with the connection point
 - the O&M cost associated with the sole use assets associated with the connection point

These charges are further adjusted by the revenue reconciliation process described below.

Calculation of Yardstick Tariffs for HV and LV networks

The starting point is the reinforcement cost model. The model is a theoretical 500MW extension to a distribution system, based on modern equivalent assets and Long Run Marginal Cost principles.

It consists of the required transformer capacity at each system level to meet demand and security to normal industry planning guidance allowing for the use of standard size equipment and typical utilisation factors. It also consists of appropriate cable and overhead lines at each voltage level to reflect the actual mix of the existing network and typical utilisation factors.

Separate costs are identified for each normal level of network and transformation and leads to a model of the network costs and yardsticks that identifies costs at:-

EHV/11kV Transformation and above – this uses the residual £/kVA from the EHV methodology detailed above converted into a £/kW.

11kV Network

11kV/LV Transformation

LV Network

For consistency with current connection policy, the yardsticks include an assumption of a shallowish charging policy and use this assumption in a forward looking manner. This makes an allowance for the customer contributions that would be paid under current connection policy up to one level up from the voltage of connection, essentially allowing model costs to be charged at lower annuity factors.

The detailed operation of this is in three steps;

1. Identify network or transformation equipment used to meet customers demand requirements.

2. Calculate the proportion of the asset cost at each voltage or transformation level that would be covered by customer contributions under the current connection policy.
3. Apply these factors at the relevant voltage levels to the £/MW cost derived from the 500MW model.

The on site sole use assets are all considered to be fully contributed to.

In addition to capital costs, the tariff model also takes account of operation & maintenance costs and other business costs, e.g. business rates...

The main elements and activities associated with network operating and maintenance costs are:-

- Network Repairs to substations (S/S), overhead lines (O/H) and underground cables (U/G).
- Network Maintenance to S/S, O/H, U/G and Tree Maintenance.
- Fault Repairs to S/S, O/H, U/G and Unmetered Supplies.
- Network Inspection to S/S, O/H, U/G.
- Network Management to the network (e.g. investigation of voltage complaints and load monitoring)
- Standby costs for emergency operation and Switching Costs.
- Dismantling of equipment – S/S, O/H, U/G
- Materials Costs

The rate for O&M is calculated as a percentage based on forecast cost and expressed as a ratio of operation and maintenance to the total asset cost. This is then applied to the modern equivalent value of the distribution assets given by the reinforcement cost model in total. Network operating and maintenance costs are included within yardstick costs expressed as the percentage of capital at each voltage level in the model. Losses are also applied in yardsticks as a percentage according to the voltage level of the network.

The fundamental objective of cost apportionment across customer classes is to:-

- Identify the incremental costs of network reinforcement by voltage across the system and express them as a £/kW/annum from the 500MW model described above.
- Identify the coincidence of the demand of the various classes of customer with system maximum demand.
- Apportion the incremental costs of the network to customer classes in line with their coincidences to obtain yardstick costs for each class to enable tariffs to be set with the correct relativity of price to underlying cost for all classes.

The 500MW model is costed at 0.95 power factor so, for customer classes where the normal power factor differs from this, a Power Factor Deviation Cost Adjustment is made.

Ongoing O&M and future replacement costs for LV and HV Connection costs are added into the yardstick by costing typical service arrangements for Domestic, <100kW Commercial & Industrial and >100kW Sites. These costs are incorporated as a p/kWh using the same apportionment method as 500MW Model costs.

500MW Model and Connection costs are converted to annualised values by applying an annuity factor based on the Rate of Return applicable for the Price Control period (currently 6.9%) over a 40 year asset life. O&M costs are included in yardsticks as a percentage of capital. For those connection assets where a capital contribution has (or is assumed to have) been paid, the annuity is adjusted so that only O&M costs are included in the yardstick for the first 40 years, with replacement capital and O&M costs assumed thereafter.

The annuity factor is calculated as:-

$$\text{RoR}/(1-(1/(1+\text{RoR})^{40}))$$

Where RoR is the Rate of Return.

Working Capital Adjustments are made to account for the lag between costs being incurred and revenue recovery in the DUoS charges.

The costs of network losses are incorporated in yardsticks as percentage uplifts to the 500 MW model costs to reflect the increase in capacity upstream from the customer necessary to meet the demand at the customer's point of connection.

The following Yardstick customers are used to determine tariffs as these represent the major types of customer;

Domestic supplies profile classes 1 and 2

Small Non domestic supplies profile classes 3 and 4

Large non domestic supplies profile classes 5 to 8 HV supplies

Large non domestic supplies profile classes 5 to 8 LV network supplies

Large non domestic supplies half hourly metered HV supplies

Large non domestic supplies half hourly metered LV network supplies

Unmetered supplies non half hourly metered

Unmetered supplies half hourly metered

Site specific charges

Licensed Distributor Tariff – Predominantly Domestic LV connected – Band 1

Licensed Distributor Tariff – Predominantly Domestic LV connected – Band 2

Licensed Distributor Tariff – Predominantly Domestic LV connected – Band 3

Licensed Distributor Tariff – Predominantly Domestic LV connected – Band 4

Licensed Distributor Tariff – Predominantly Domestic HV connected

Reconciliation of LRIC and DRM output to required revenue

Our required revenue associated with demand use of the network is split between EHV networks and lower voltage networks in the following way:

- Excluding rates and NGET exit charges the required revenue is split between the EHV network and lower voltage networks using a modern equivalent asset (MEA) valuation.
- Asset quantities used for this evaluation are consistent with those contained in our Regulatory Reporting Tables together with MEA assets values used for our long term investment planning
- NGET exit charges are recovered with the reconciliation of the LRIC part of the model
- At the EHV level reconciliation will be made by a £/kVA adder using the winter total kVA
- Averaged £/kVA from the EHV model at the 33/11kV level will be used to populate the top levels of the DRM
- Reconciliation of the DRM to required revenue will be achieved by uniform percentage scaling, excluding the parts derived from the LRIC model except in the case of predominantly domestic LV IDNO tariffs. In the latter case the p/kWh scaling applicable in the predominantly domestic HV connected IDNO tariff will also be applied at the LV level.
-

Both the LRIC and DRM parts of the model recover forecast network rates in proportion to the revenue recovered.

The generation incentive under our price control results in the following treatment:

- Once set, EHV generator charges will be capped to a change no greater than 10% in any 12 month period
- For new EHV generators, a £/kVA adjustment will be applied to all generators with accepted connection offers for the year charges are being set for to meet allowed revenue excluding over/under recoveries from previous years under the generator incentive
- Due to the continuing low level of generation connections to the HV and LV networks and hence the potential for volatile charges, the 10% price movement per annum cap in the existing methodology will be retained for HV and LV generator charges
- For the avoidance of doubt, the capping arrangements to generator charges will only apply until 31st March 2010 subject to review.
- A 10% price movement per annum cap will be applied to HV and LV generator charges.

Where after the revenue reconciliation process the resulting EHV demand charge is negative, the £/kVA charge applicable to that demand site will be set to zero and the overall reconciliation to required revenue adjusted accordingly.

Setting Prices using the LRIC/DRM Model

Within tariffs, Fixed Availability (Profile 5-8) and Half-hourly Availability charges are set to recover, for a typical customer, the O&M costs of the connection and local system assets in

the first 40 years, ongoing capital replacement and O&M of the connection assets thereafter, with capital and O&M of local transformation and system costs. Once agreed, the agreed capacity that is used for availability charges for half-hourly sites, will normally be fixed for a minimum of one year unless increased by agreement with WPD. In such cases the increased capacity will normally be fixed for a minimum period of a year from the date of increase. For EHV demand sites the fixed charge is set to recover the marginal charge as determined under the LRIC approach plus the annuitised cost of the future replacement and O&M costs of all sole use assets; both on site and off site. The charge per kVA per day is set to recover all other costs including the £/kVA adder applied within the LRIC approach. For EHV customers with power factors worse than 0.95 the charge will show the reduction in charge that would result from operating at an improved power factor. For EHV generation sites, charges will be recovered on a charge per kVA per day basis.

For DRM derived tariffs the Reactive Power charges are calculated based on the power factor deviation cost in the yardstick. This provides a yardstick incremental p/kWh for each 0.01 reduction in power factor. The tariff for half-hourly metered demand is based on charging for kVAh in excess of half the number of kWh supplied. The relationship between the number of kWh supplied and the number of excess kVAh supplied enables the cost in p/kWh to be converted into a cost in p/kVAh across the typical range of power factors.

An example of a DRM yardstick and scaling is included at Appendix 2.

Individual tariffs are set with types of charges that depend on the size of the customer, the complexity of the metering installed and the method of billing. Thus profile 1 to 4 sites may comprise fixed charges and unit charges although the fixed charges may be zero. Profile 5 to 8 fixed charges for Availability plus unit charges and half-hourly billed sites may have p/kVA/day Availability charges based on agreed connection capacity, fixed charges, unit charges and reactive power charges.

Generator Use of System Charges at HV and LV

Ofgem have proposed a mechanism to incentivise WPD (Wales) plc to connect distributed generators to its electrical network. The mechanism allows WPD (Wales) plc to recover a percentage of the reinforcement costs associated with connection of generation, a value per kW of generation connected and the operation and maintenance on the sole use and reinforcement assets either from the individual generator or the population of generators. This approach involves the creation of a generation regulatory asset base and the development of a distributed generation (DG) allowed revenue income stream. This methodology explains the calculation of use of system charges for distributed generation connected from April 1st 2005

No charges will be made in relation to generators connected prior to 1st April 2005. If a generator connected prior to April 1st 2005 makes a significant alteration to their export requirement (due to, for example, increased export capacity) only the incremental increase in export capacity will be charged generator use of system.

Model Inputs and Assumptions

The following assumptions are applied in the calculation of a generator use of system charge:

- Ofgem determined in the Final Determination document from November 2004 that the allowed rate of return for the price control period from 1st April 2005 to 31st March 2010 is 6.9%;
- The overall level of reinforcement costs are as assessed during the price control determination for generator charging.
- The operation and maintenance rate used demand DUoS calculation is applied on the sole use and reinforcement assets. The standard rate is calculated as percentage of the operation and maintenance costs of the modern equivalent value of the distribution assets;
- The pass through rate for the value of reinforcement assets has been defined by Ofgem as 80%;
- The value of incentive rate is defined by Ofgem as £1.50 per kW of generation connected; and
- The assets utilised for connection of generation will be depreciated over 15 years.
- Generator use of system will be an annuitised charge.
- Costs are assessed using the reinforcement costs from the 500MW model costs for the voltage of connection of the generator.
- The Network Charge will be based on forecasted Distributed Generation capacity for the 2005-2010 period.

Model Outputs

WPD (Wales) plc will set prices for the Network Charge based on projected reinforcement costs associated with connecting a certain level of distributed generation. The Network Charges are set for the whole DNO area. The Network Charges will be adjusted each year to take account of any RPI adjustment in the DG Price Control.

When a distributed generator accepts a connection offer, the applicable Agreed Export Capacity will remain fixed for 5 years.

The Network Charges for generators requiring half-hourly metering will be on a per kVA basis. For other generators the Network Charges will be on a pence-per-day basis.

WPD (Wales) plc will set prices on an annual basis to recover and not to exceed the projected Distributed Generation (DG) Allowed Revenue. While the charges are set using an initial forecast of connected capacity and costs over the first five years, actual activity will be used to adjust the forecast and the under or over recovery, if material, will lead to an adjustment in charges. The Network Charges will be reviewed on an annual basis. Basing the charge on a five year forecast smoothes the annual charge and minimises volatility in the charges. In addition, a limit of 10% change in a 12-month period is applied to HV and LV generation charges. As there have been no system reinforcement costs associated with microgeneration connected to premises supplied under profiles 1 to 4, nor are any forecast for a number of years, generation charges for these premises will be set to zero.

Price Setting

For example, assuming that reinforcement costs of £50/kW are the cost reflective level for charging:-

The annual charge would be set at:

$£50 * 80% * 10.91% = £4.36/\text{kW}/\text{year}$ plus incentive (£1.50/kW) plus O&M (£1.00/kW)

Total £6.86/kW/year, where 80% is the pass through factor and 10.91% is the annuity at 6.9% return over 15 years.

Charges for half-hourly metered generation would reflect the £6.86/kW/annum (or 1.85p/kW/day) with some variation by voltage of connection by applying yardstick weightings and adjusting to a charge as a p/kVA/day.

For example, if the forecast connected generation at HV was 2000kVA and at LV was 500kVA and the 11kV yardstick were £3.60 /kW/yr and LV £6.25/kW/yr, then

$$3.6 * x * 2000 + 6.25 * x * 500 = 6.86 * 2500, \text{ giving } x \text{ as } 1.66,$$

and an HV charge of £5.68/kVA/annum and an LV charge of £9.86/kVA/annum.

In this case, the indicative charges for half-hourly metered generation would be 1.56 p/kVA/day for HV and 2.70 p/kVA/day for LV connections.

For non-half-hourly generators indicative charges would be:-

7.06p/MPAN/day for Profile 5 to 8 assuming the average capacity installed were 15kVA.

Incentive for Network Access - HV and EHV connected Generation

WPD (Wales) plc will, by prior agreement with generators connected after April 1st 2005, rebate generators for network unavailability where the individual connection has suffered network interruption at a frequency and duration higher than designed, taking into account the degree of firmness of the individual connection design agreed between WPD (Wales) plc and the generator.

The rebate will take the form:

Rebate rate x Generator Capacity x (network interruption duration - baseline network interruption duration), subject to a de minimus level of rebate to allow for the costs of administration.

The rebate rate will have a default value as defined in the distribution licence or an alternative value agreed between WPD and the generator. In any case, the value of the rebate will be capped at the level of annual Network Charges (GDUoS).

The network interruption includes occurrences of a physical break in the distribution circuit between the generator and the rest of the distribution system that prevents the generator from exporting power. It will exclude 50% of pre-arranged outages of distribution equipment for

which statutory notification has been given to the generator, and other exemptions as allowed in the quality of service incentive and as agreed between WPD and the generator.

The baseline network interruption duration will have a default value of zero or an alternative value agreed between WPD and the generator.

The calculation and administration of the rebates will be undertaken between WPD and the party holding the Use of System Agreement for the site on an annual basis.

The rebate will apply only to HV and EHV connected generation.

The de minimis level of rebate is defined in the Charging Statement.

Glossary

the Act	The Electricity Act 1989 as amended by the Utilities Act 2000
the Licence	The Electricity Distribution Licence granted to Western Power Distribution (Wales) plc under Section 6 (1) (c) of the Act
the Authority	The Gas and Electricity Markets Authority (GEMA) as established by the Act
OFGEM	The Office of Gas and Electricity Markets
WPD (Wales) plc	Western Power Distribution (Wales) plc
NGET	National Grid Electricity Transmission – who own and operate the transmission network in England and Wales
MRA	Master Registration Agreement – the multi-party agreement that all Licensed Suppliers and Distributors have entered into that governs the interactions between them
BSC	Balancing and Settlements Code – wholesale electricity trading arrangements introduced in England and Wales in 2001
Distribution Code	The Distribution Code of the Distributors of Great Britain (www.dcode.org.uk); produced in accordance with Condition 9 of the Licence and approved by the Authority to define the technical aspects and planning criteria of the working relationship between the Distributor and all those connected to its distribution system
EHV	Extra High Voltage – A voltage of 22kV or above or at a sub-station with a primary voltage of 66kV or above.
HV	High Voltage – 6,600 volts or 11,000 volts plus or minus 6% measured between any two phase conductors
LV	230 volts plus 10% or minus 6% measured between the neutral and any phase conductor
S/S	Electricity Substation – voltage transformation points
O/H	Overhead Lines
U/G	Underground Cables
O&M	Operation, Repair and Maintenance
DG	Distributed Generation
MPAN	Meter Point Administration Number
LTDS	Long Term Development Statement as required under SLC 25
NER P2/6	System security standard applicable to the network in accordance with SLC 5
LRIC	Long run incremental cost methodology use to derive charges for the EHV network
DRM	Distribution reinforcement model used to derive charges for the HV and LV networks

Western Power Distribution (Wales) plc
Registered office: Avonbank, Feeder Road, Bristol, BS2 0TB
Registered in England and Wales No 2366985

PUBLISHED BY WESTERN POWER DISTRIBUTION (Wales) plc

Appendix 1

Example of LRIC method

Taking a simple two feeder network as follows:

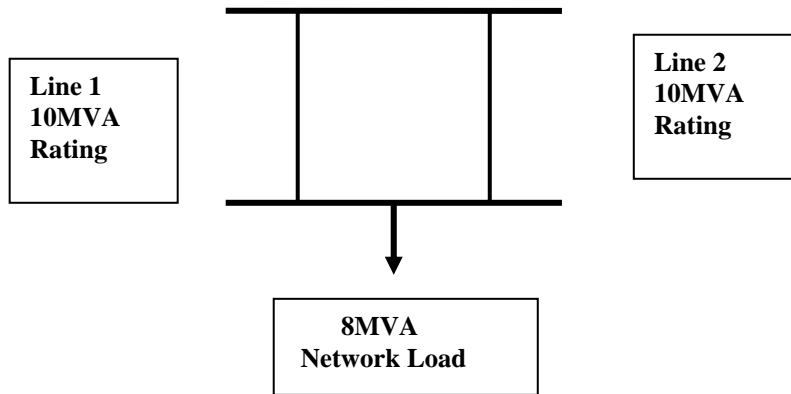

The long run incremental cost is given by:

$$LRIC_N = \sum_1 \Delta U_1 = 2 \times 4,465 = \text{£}8,950/\text{MVA}$$

Where:

ΔU_1 is the change in the net present value of the future reinforcement cost of each feeder as a result of the incremental injection of 1MVA (ΔP_{ln}) (this will be shared equally by the two feeders) given by the equation

$$\Delta U_1 = A \times V \times \left(\frac{1}{(1+d)^{n2}} - \frac{1}{(1+d)^{n1}} \right) = 0.0831 \times 200,000 \times \left(\frac{1}{(1+0.069)^{10.6}} - \frac{1}{(1+0.069)^{22.4}} \right)$$

$$= \text{£}4,465/\text{MW}$$

Where:

A is a 40 year annuity calculated as

$$A = \frac{d}{1 - \left(\frac{1}{(1+d)^{40}} \right)} = \frac{0.069}{1 - \left(\frac{1}{(1+0.069)^{40}} \right)} = 0.07414 \text{ i.e. } 7.41\% \text{ plus a } 0.9\% \text{ O\&M uplift} = 8.31\%$$

V is the cost of the reinforcement when the asset becomes overloaded, £200,000

d is the discount rate (the regulatory cost of capital of 6.9% is used)

n1 is the original number of years to reinforcement given by

$$n1 = \frac{\log C_1 - \log D_1}{\log(1 + r)} = \frac{\log 5 - \log 4}{\log(1+0.01)} = 22.4 \text{ years}$$

Where:

C1 is the capacity of asset 1, 10MVA

D1 is the power flow in asset 1, 4MVA and

r is the expected growth rate, 1%

and n2 is the new number of years to reinforcement following a change in the flow of 0.5MVA (as increase in load at node of 1MW will be equally shared between the two feeders) (ΔP_1) through asset 1 as a result of the injection at node N is given by

$$n2 = \frac{\log C_1 - \log (D_1 + \Delta P_1)}{\log(1 + r)} = \frac{\log 5 - \log(4+0.5)}{\log(1+0.01)} = 10.6 \text{ years}$$

Appendix 2

Appen

Example of Yardstick	Profile 1		WPD Wales	
kWh/kW	3662		£/kW/yr	p/kWh
33/11kV Substation			29.32	0.729
33/11kV S/S Losses	@	4.97%		0.036
11kV System			19.23	0.478
11kV System Losses	@	4.19%		0.020
11kV/LV Substation			3.98	0.103
11kV/LV S/S Losses	@	2.86%		0.003
LV System			7.36	0.191
LV System Losses	@	0.93%		0.002
Total 500MW Model Costs				1.562
Power Factor Deviation Cost				-0.078
Service Cost			2.08	0.057
Subtotal				1.541
Total Network Costs				1.541
Plus Working Capital	@	0.773%		0.012
Operational Rates (attributed to the LRIC part of the model)				0.092
Operational Rates (attributed to the DRM part of the model)				0.095
Total Yardstick				1.740
Scaling (Not applied to the LRIC parts of the model)			149%	
Scaled Yardstick				2.17

Note: An adjustment for customer contributions has been applied at the LV system level and has a value of 50%.

Appendix 3

1. Loss Adjustment Factor Methodology

- 1.1. This appendix describes the methodologies applied by Western Power Distribution (WPD) in the calculation of its loss adjustment factors for authorised users of its distribution network in 2006/2007.
- 1.2. WPD is not required to publish a statement detailing its methodology for the calculation of its published loss adjustment factors but has chosen to prepare this statement to provide clarity and transparency. This appendix is not approved by and is not subject to approval by the Authority.
- 1.3. WPD is obliged by Standard Condition 4A clause 2 (b) of the Distribution License to publish a “schedule of adjustment factors” in our Condition 4A statement.
- 1.4. WPD’s loss adjustment factors are determined through the application of two methodologies. Generic loss adjustment factors are calculated using the methodology and software developed in the late 1990s by EA Technology, in conjunction with several other distribution businesses from England & Wales. For a number of customers, generally those connected at EHV or with demands close to or above 10MW and those CVA registered users LAFs are individually calculated.

2. Calculated System Losses

- 2.1. Losses fall into two categories, fixed losses and variable losses. Fixed losses are dependent on the presence of voltage differences and do not vary significantly with load. The most significant contributions to fixed losses come from iron losses in transformers and dielectric losses on the 132kV system. Variable losses vary with the magnitude of the current such as ohmic losses in conductors and transformer windings.
- 2.2. In order to calculate the LAFs, a fixed loss constant and a variable loss constant are required. The value of each loss constant is directly linked to system configuration. Therefore, any alterations or additions to the electrical network will result in an adjustment to the value of the fixed and the variable loss constants.
- 2.3. The fixed and variable loss constants are derived from system data such as length of underground cable and overhead line network, number of feeders and transformer capacity.
- 2.4. The total annual system losses are the difference between the annual units supplied at the connection points with National Grid together with the contribution from Distributed Generation within WPD’s distribution network and the annual units sold. The EA Technology model allocates these losses to the units distributed at the various voltage levels, after making an allowance for unmetered usage. LAFs can then be calculated which recover the losses attributable to unit consumption within each tariff period at each voltage level.

3. Site Specific Loss Adjustment Factor Methodology

- 3.1. Site Specific Loss Adjustment Factors are calculated for a number of customers, generally those connected at EHV or with demands close to or above 10MW and those CVA registered authorised users.

- 3.2. Individual LAFs are calculated for each half hour using individual customer's half hourly load profiles at the appropriate voltage level. Mean LAFs are then allocated to the different tariff periods as indicated below:

Period 1	1600 -1900 Mon - Fri Nov - Feb'
Period 2	0630 - 1600 Mon - Fri Nov - Feb'
Period 3	2330 - 0630'
Period 4	Other

4. Generic Loss Adjustment Factor Methodology

- 4.1. Generic loss adjustment factors are calculated for all remaining SVA registered authorised users. The allocation methodology and software program developed by EA Technology in the late 1990s is utilised to calculate the generic loss adjustment factors.
- 4.2. The voltage levels of 132kV, 66kV, 33kV, 11kV and LV and the transformation levels are represented within a network model. The model is populated with the set of standing data. For example, the fixed loss constant in megawatts and the variable loss constant per megawatt for each voltage and transformation level are contained within the standing data.
- 4.3. The model is also populated with the metered volumes of energy per annum at the various network voltages, including the energy metered at the connection points with National Grid Company and the contribution from Distributed Generation within WPD's distribution network. This metered data is transformed into half-hourly data using the settlement profiles, Profile Classes 1 to 8.
- 4.4. Loss Adjustment Factors are calculated at all voltage levels for every half hour period throughout the year.
- 4.5. As a simple overview, the 'LAF' program determines the power passed through the network into the voltage level below by:

$$P_{out} = P_{in} - v \times P_{in}^2 - f - L$$

Where:

P_{in} = Power into voltage level from higher voltage level

P_{out} = Power out of voltage level into lower voltage level

L = Half hourly metered net sales at voltage level

f = Fixed loss constant for voltage level

v = Variable loss constant for voltage level

- 4.6. This is repeated through the voltage and transformation levels until the LV network is reached. This produces the first estimate of the LV network non half-hourly metered load in every half-hour. As we have used the settlement profiles, these values will differ from the meter readings and therefore the program undertakes a series of iterative cycles to match the two values.

- 4.7. The program adjusts the variable losses by amending the variable loss constants. Greater weight is assigned to the 11kV network, 11kV/LV transition and LV network as the greatest losses are generated at these networks coupled with the greatest uncertainty in the losses figures.
- 4.8. This results in the losses for the whole period and the losses for each half-hour for each voltage and transformation level being calculated and therefore the half-hourly loss adjustment factors are calculated.
- 4.9. Within Western Power Distribution, there is an overall target loss figure that is typically 6.1% for the Wales as a percentage of imports.

5. Contact Details

- 5.1. This statement has been prepared to provide clarity and transparency for users of WPD's distribution network. If you have any questions about the contents of this statement, please contact the relevant person at the address shown below.

Lee Saville
Western Power Distribution
Avonbank
Feeder Rd
Bristol
BS2 0TB
Tel: 01179332299
e-mail: lsaville@westernpowerco.uk